

Crandall Office Furniture

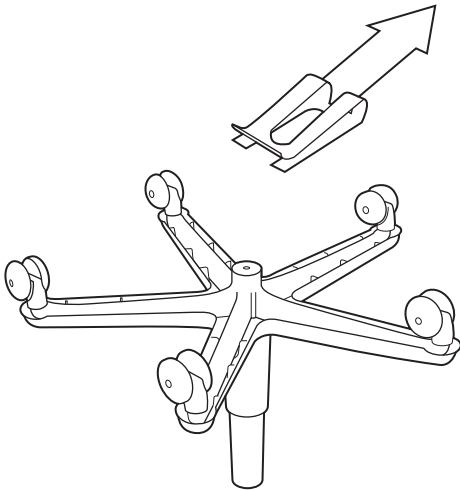

Criterion Gas Cylinder

- 1) Remove retaining clip at center of star base using a flathead screwdriver and lift base off of support tube to expose gas cylinder.



- 5) Using a 3/4" to 7/8" pipe lightly tap new lock ring into place making sure to center the gas cylinder inside of the support tube.

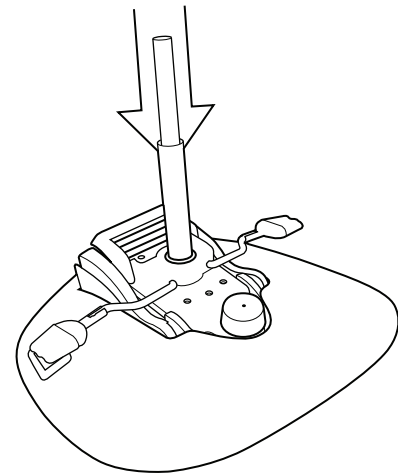

- 2) Using a small flathead screwdriver remove the ring locking cylinder in support tube and pull gas cylinder out of tube. Note: You will not be able to re-use this ring but a new lock-ring is provided with your new gas cylinder kit.

- 6) Place washer, bearing, and second washer over end of gas cylinder strut.

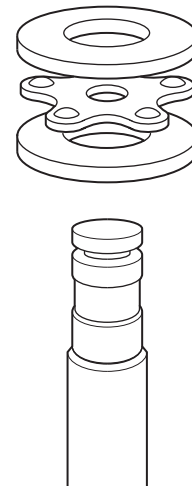
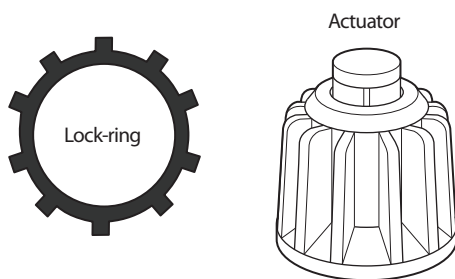

- 3) Turn chair over and shake actuator out of tube. The pin must move freely for cylinder to work properly.

- 4) Place the actuator and the new gas cylinder back into the support tube and ensure that the cylinder is seated correctly.

- 7) Replace star base and retaining clip. Test cylinder connections by lifting chair by the seat before using.